

FERROVAC GMBH

ULTRA HIGH VACUUM TECHNOLOGY

DRVRMOTL

Motorized Linear Drive

DRVRMOTLR

Motorized Linear and Rotary Drive

DRVRMOTLRR

Motorized Linear and Double Rotary Drive

Instruction

Manual

Version 1.1

06 September 2016

THURGAUERSTR. 72, CH-8050 ZÜRICH, SWITZERLAND

TEL. +41 44 273 16 38, FAX. +41 44 273 16 30

WWW.FERROVAC.COM, SALES@FERROVAC.COM

Warranty

Ferrovac GmbH warrants this product to be free of defects in material and workmanship for a period of 12 months from the date of shipment.

In case of proof of any defective parts in the product, we will at our option, either repair the product or replace it.

Warranty Limitations

The warranty for this product does not apply to defects resulting from the following:

- non-observance of operational- and safety instructions
- natural wear of components
- modifications to our products without our written consent
- misuse of any product or part of the product

This warranty stands in place of all other warranties, implied or expressed, including any warranty of merchantability implied or fitness for a particular use. The remedies provided herein are buyer's sole and exclusive remedies.

Neither the company Ferrovac GmbH nor any of its employees shall be liable for any direct, indirect, incidental, consequential or special damages arising out of the use of its products, even if the company Ferrovac GmbH has been advised in advance of the possibility of such damages. Such excluded damages shall include but are not limited to: Costs of removal and installation, losses sustained as the result of injury to any person, or damage to property.

Copyright

Copyright 2014, Ferrovac GmbH. All rights reserved. All information in this document is the sole property of Ferrovac GmbH and is protected by Swiss copyright laws and international conventions.

Ferrovac GmbH grants the right for reproduction for the purchasers own use. No part of this manual may be reproduced or transmitted by any third party in any form or by any means and for any purpose without the written permission of Ferrovac GmbH.

Content

WARRANTY	2
WARRANTY LIMITATIONS	2
COPYRIGHT	2
CONTENT	3
TERMS AND SYMBOLS	4
NORMAL USE	4
1. INTRODUCTION	5
1.1. DRVRMOTL	5
1.2. DRVRMOTLR	5
1.3. DRVRMOTLRR	5
2. UNPACKING AND INSPECTION	5
3. OVERVIEW	6
3.1. NOMENCLATURE	7
3.2. HANDLING & ADJUSTING OF THE LIMIT SWITCHES	8
3.2.1. FRONT LIMIT SWITCH	8
3.2.2. REAR LIMIT SWITCH	9
3.2.3. ROTATION LIMIT SWITCHES	9
3.3. MOUNTING	11
3.4. TUBE SUPPORT	11
3.5. BAKEOUT	12
4. PROBLEM SOLVING	13
4.1. FACTORY OVERHAUL	13
4.2. DECLARATION OF DECONTAMINATION	13
4.3. DOWNLOAD	13

Terms and Symbols

The information in this document represents the state of the product at the date of print. Technical changes may be made without notice. Ferrovac GmbH makes no warranties or representations with respect to accuracy or completeness of the contents of this publication. Figures and photos are not binding. The used product names are for identification purposes and may be trademarks of their respective companies.



A triangle with explanation mark indicates a passage in the manual with information that is crucial for the operator. **READ THESE PARAGRAPHS CAREFULLY** or the product might be damaged by misuse.

CAUTION! The CAUTION heading in a manual explains hazardous situations that could damage the product. Such damage may invalidate warranty.

Normal Use

The product described in this manual must always be used:

- With original accessories supplied by Ferrovac which are explicitly specified for the use with the product described in this publication.
- In an indoor research laboratory environment.
- By personnel qualified for operation of delicate scientific equipment.
- In accordance with this and all related manuals.



CAREFULLY READ THE SAFETY INFORMATION AND ALL RELEVANT MANUALS BEFORE USING THE PRODUCT AND ANY RELATED INSTRUMENTATION!

1. Introduction

1.1. DRVRMOTL

Motorized linear and manual rotary drives are designed to operate sample transporters and optionally attached sample locking mechanisms such as a pincer grip. The DRVRMOTL linear drive is compatible with RM40, RMD40, RMDG40 and GMD40. For these sample transporters, a variety of Ferrovac sample receivers, carriers and pincers are available. The motorized linear drive still allows for manual rotation of the shaft for sensitive application of the rotation of your sample holder or when opening/closing the pincer. Rotation can be locked using a thumbscrew.

1.2. DRVRMOTLR

Motorized linear and rotary drives are designed to operate sample transporter and optionally attached sample locking mechanisms such as a pincer grip. The DRVRMOTLR linear and rotary drive is compatible with RM40, RMD40, RMDG40 and GMD40. For these sample transporters, a variety of Ferrovac sample receivers, carriers and pincers are available. Single rotation and linear movement is completely motorized. Thus opening/closing of pincers or rotation of your sample carrier is easily done from your workstation.

1.3. DRVRMOTLRR

Motorized linear and rotary drives are designed to operate sample transporters and to optionally attached sample locking mechanisms such as a pincer grip. The DRVRMOTLRR linear and double rotary drive is only compatible with RMDG40 sample transporters (as only this model has two rotatable axis). For this sample transporter a variety of Ferrovac sample receivers, carriers and pincers are available. Double rotational axis and linear movement is completely motorized. Thus opening/closing and rotation of pincers or rotation of your sample carrier is easily done from your workstation.

2. Unpacking and Inspection

Motorized sample transporters are shipped clean and ready to use in UHV. Prepare a sufficiently clean workspace and wear surgical gloves when unpacking and inspecting the device. Check for any visible damage of the package, manipulator and accessories. Compare the contents of the package with the delivery note. Any damage or missing items must be reported to Ferrovac **within 48 hours after delivery**.

CAUTION!

- **Always** use powder-free examination gloves during unpacking to avoid contamination.
- **Please** ensure enough working space for unpacking and inspection.
- **Please** clean the working table/surface and cover it with Aluminium foil or household foil.
- **Never** hit the knife edge nor the bellows.
- **Never** expose the Sample Transporter to physical shocks (**brittle magnets!!!**).
- **Never** bend the tube nor the shaft.

3. Overview

The main purpose of RM40, RMD40, RMDG40 and GMD40 sample transporters with motorization is to transfer samples over longer distances.

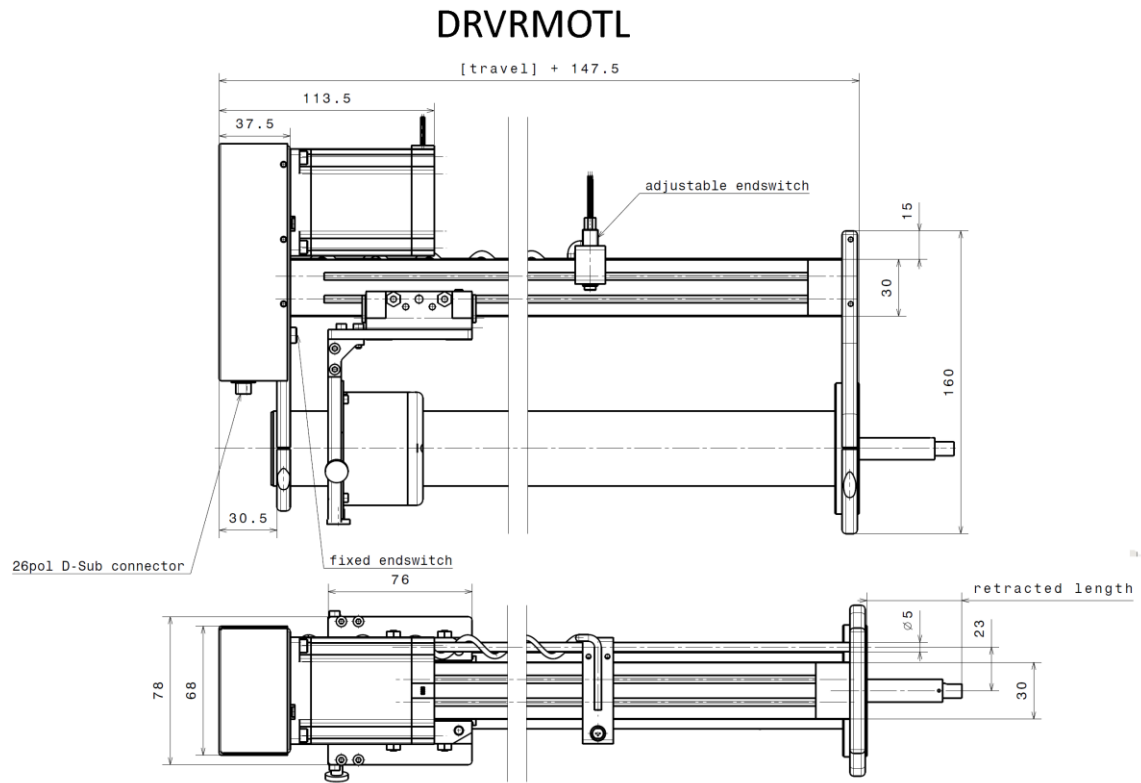

Fig. 1; Sample Transporter with Linear Motorization RM40-XXXX-YYYY-DRVRMOTL

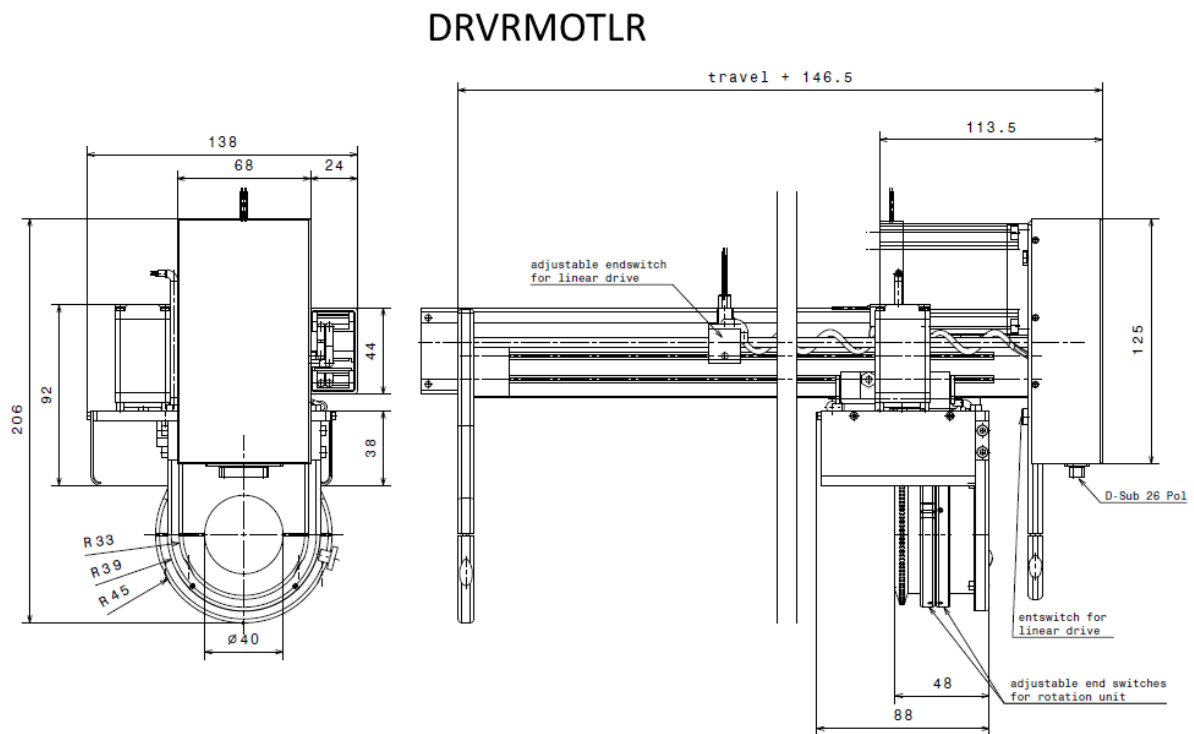

Fig. 2; Single Rotation & Linear Sample Transporter Motorization DRVRMOTLR

DRVRMOTLRR

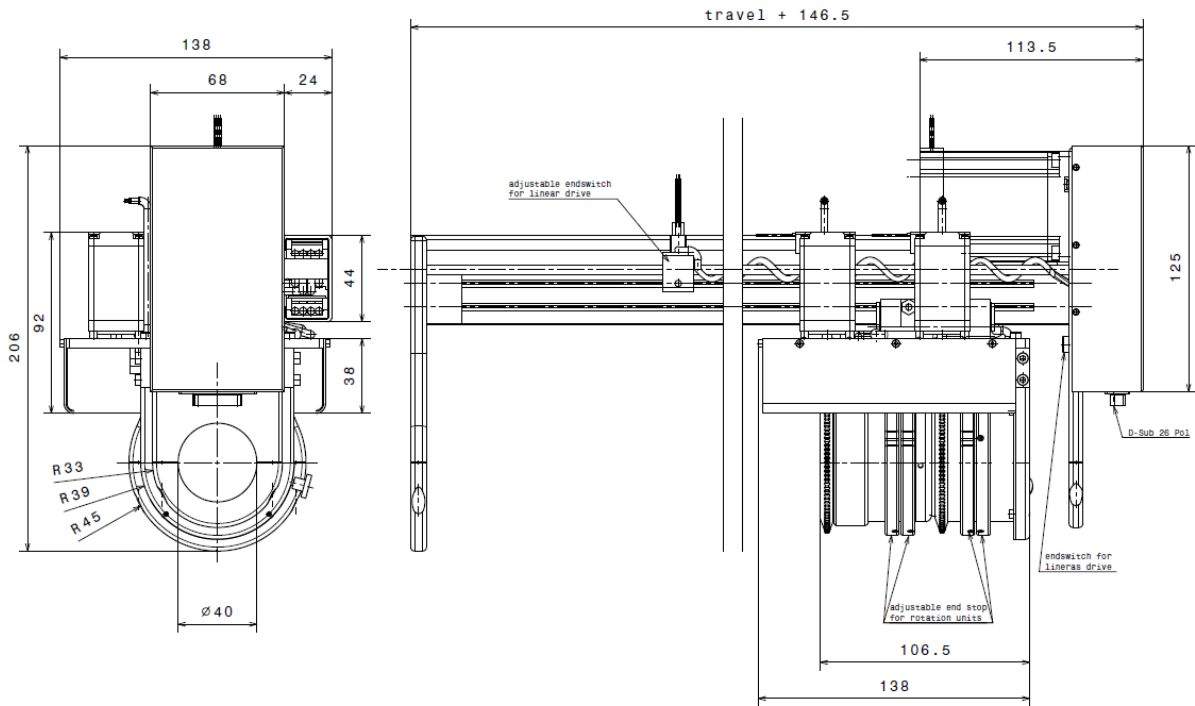

Fig. 3; Double Rotation & Linear Sample Transporter DRVRMOTLRR

3.1. Nomenclature

The main parts of the linear motorization DRVRMOTL are named as follows:

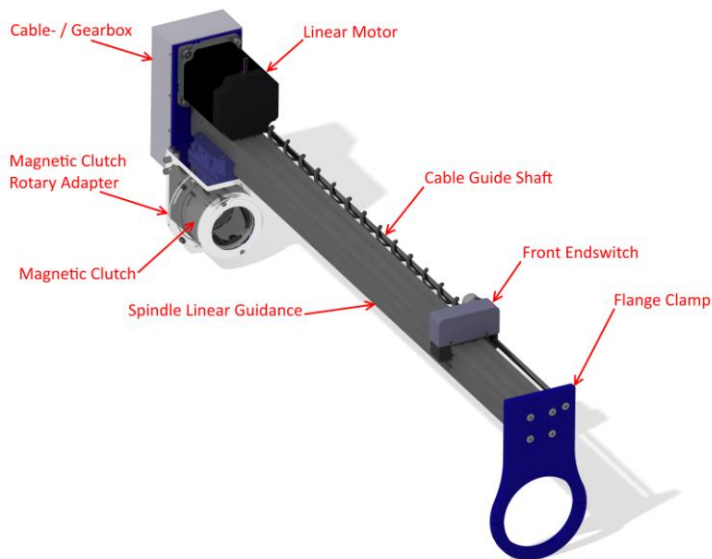

Fig. 4; DRVRMOTL Nomenclature

The main parts of the double rotary motorization DRVVMOTLRR are named as follows:

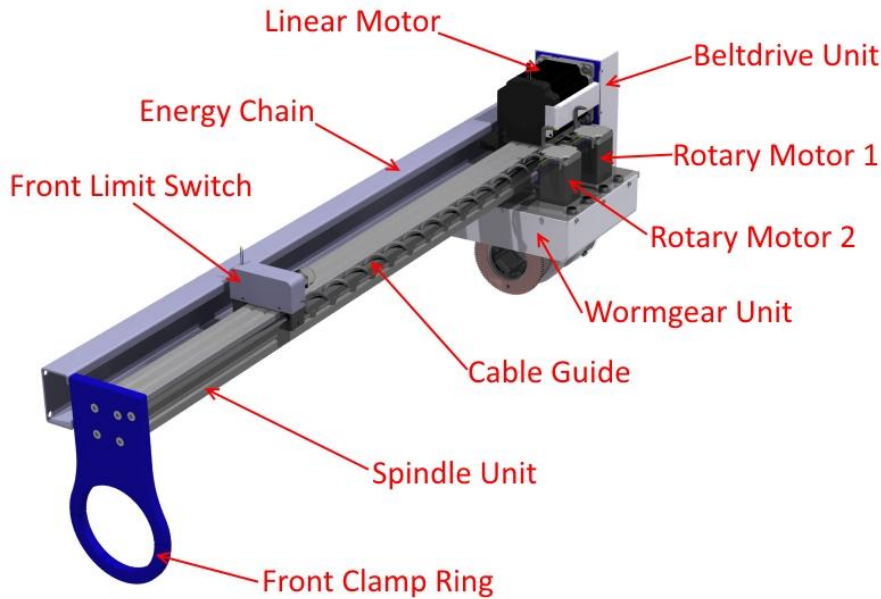

Fig. 5 DRVVMOTLRR Nomenclature

The same nomenclature applies to the single rotary motorized DRVVMOTLR.

3.2. Handling & Adjusting Of the Limit Switches

3.2.1. Front Limit Switch

All motorizations for Ferrovac sample transporters have an adjustable limit switch, with which you can define your max. extended length of the sample transporter. Undo the small screw on the side of the limit switch housing to adjust it's position.

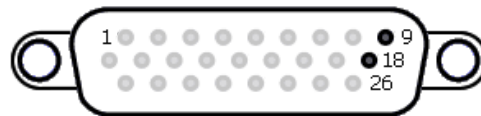
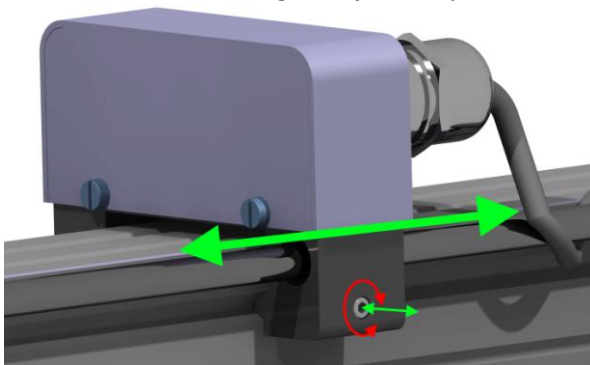

The front limit switch of all sample transporter motorizations (DRVVMOTL, DRVVMOTLR, DRVVMOTLRR) is connected to pins 9 and 18 on the 26P D-Sub connector.

Fig. 6; Front Limit Switch

The switch is a reed switch, which is operated by an applied magnetic field. This switch is normally closed wired and opened by the switch action (position is reached).

3.2.2. Rear Limit Switch

You find the rear limit switch at the rear end of the motorization (directly under the spindle unit). The position of it is not adjustable.

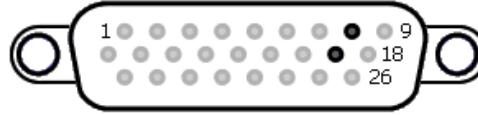
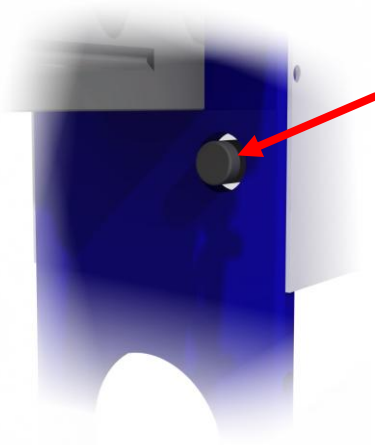

The front limit switch of all sample transporter motorizations (DRVRMOTL, DRVRMOTLR, DRVRMOTLRR) is connected to pins 8 and 17 on the 26P D-Sub connector.



CAUTION: Risk of squashing/crushing!
Never touch the motorized sample transporter during movement!

3.2.3. Rotation Limit Switches

Each rotational unit has two limit switches (start- & end-position). The start- and the angle of the end-position can easily be adjusted by 3 grub screws (3 screws/position).

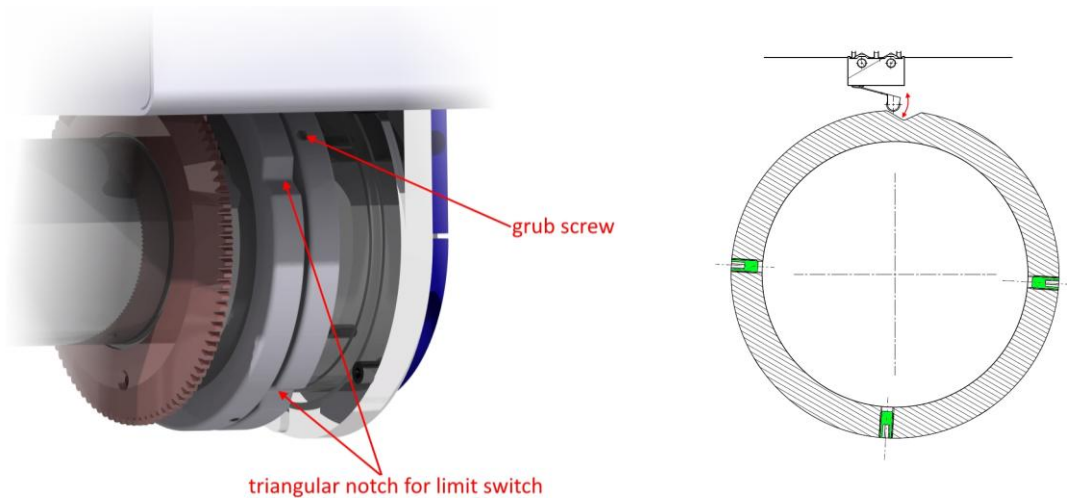

Fig. 7; Rot. Limit Switch DRVRMOTLR

For the DRVRMOTL & DRVRMOTLR motorizations, the switches can also be connected as "normal open". However, it is highly recommended to connect as "normal closed"!



CAUTION: Risk of squashing/crushing!
Never touch the motorized sample transporter during movement!

Please pay good attention to the wiring of the DRVRMOTLRR. The limit switches are wired as follows:

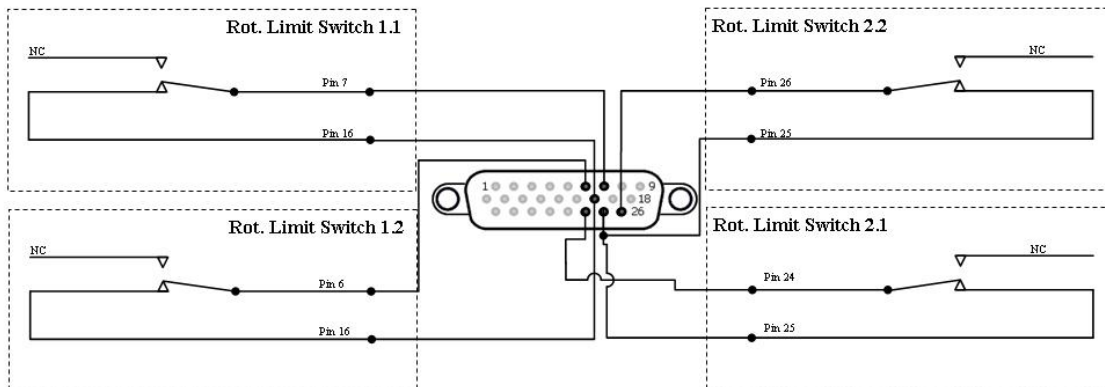

Fig. 8; Schematic Rot. Limit Switches DRVRMOTLRR

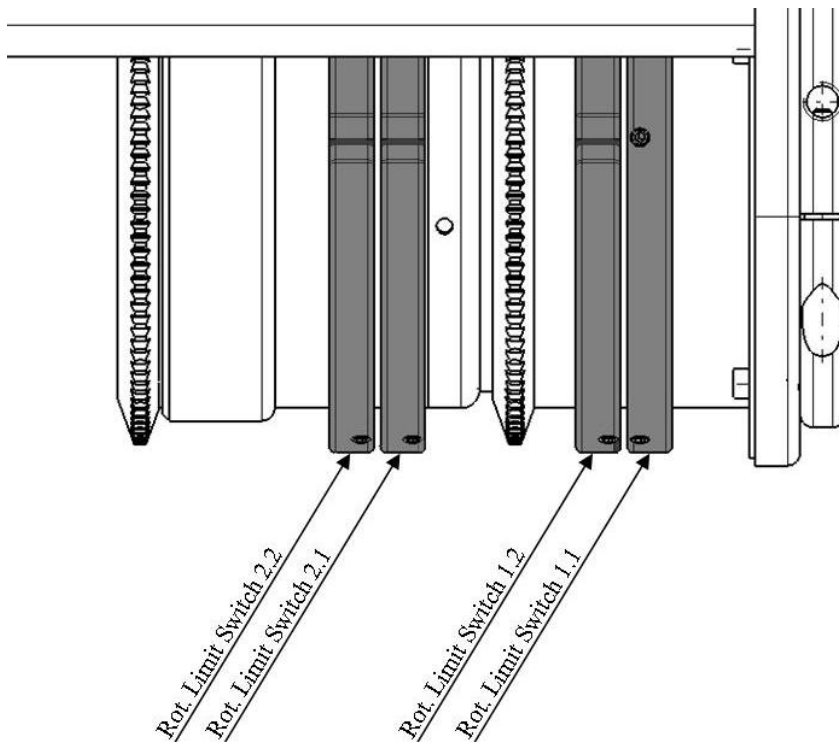

Fig. 9; Numeric Rot. Limit Switches DRVRMOTLRR

If you want to rotate your pincer, both rotational units (Motor 1 and 2) must turn in the same direction. To open or close your pincer, motor 1 must rotate and motor 2 holds it's position.



CAUTION: The rotation limit switches are only electric and don't function as as a mechanical limit stop! Ferrovac rejects all liability in case of incorrect use or adjustment.

Setup and Installation

3.3. Mounting

In delicate situations, the mounting procedure exposes the sample transporter and the motorization to the risk of being damaged. Please follow the warning notes and the illustrated instructions.

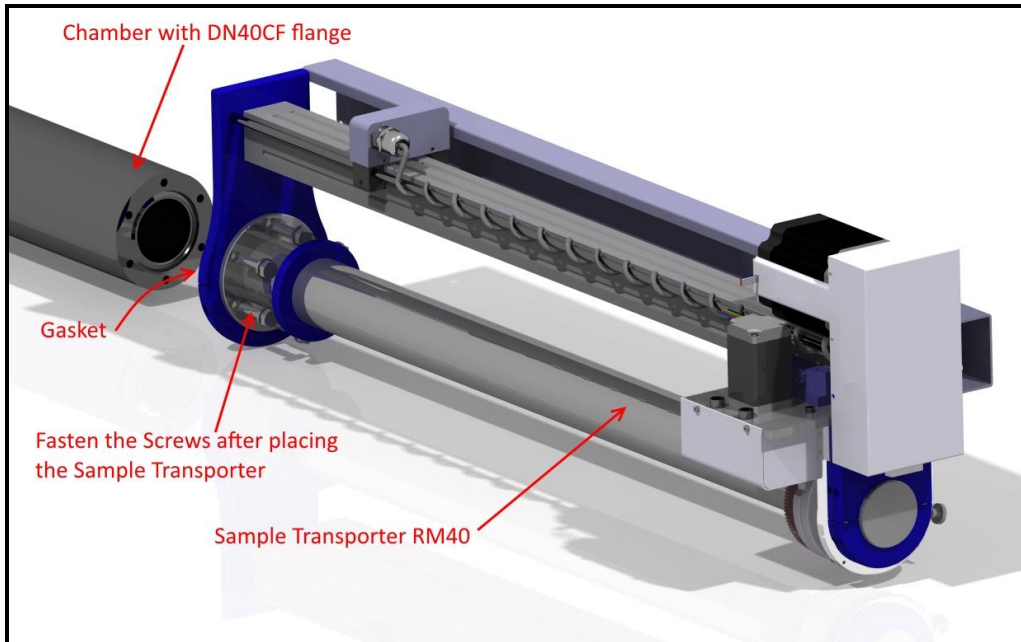

CAUTION!

- **Always** use powder-free examination gloves during mounting to avoid contamination.
- **Never** expose the Sample Transporter to physical shocks (**brittle magnets!!!**).
- **Never** bend the tube nor the shaft.
- **Never** hit the knife edge.

3.4. Tube support

Especially sample transporters with longer travel ranges require special care to be taken so that the operators do not accidentally bend the tube while the sample transporter is not in use. Also the resulting leverage in case of high weight can bend the shaft or break the flange. The support is simply mounted to the blue plate at the end of the motorization with two screws (Order Code TSRMB)

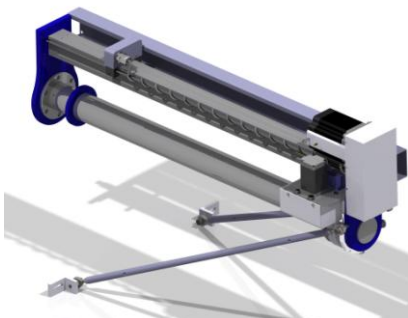
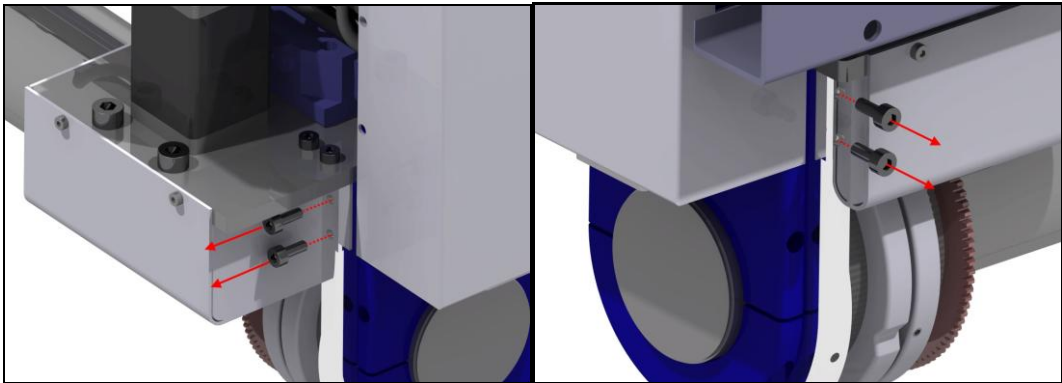

Fig. 10; Tube support TSRMBD for motorized Sample Transporter

3.5. Bakeout

The motorization is not bakeable! Follow the following steps to remove it:

1. Remove the two screws on the left and right side on the guide carriage.



2. Remove the two screws on the front and at the back of the motorization. Don't carry out this step alone! Work as a couple, one person holding the motorization while the other person undoes the screws.

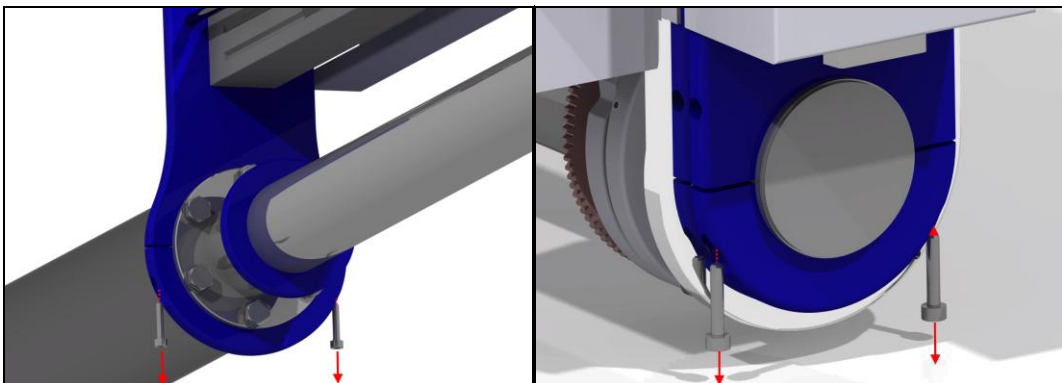

3. Lift the complete motorization unit carefully.

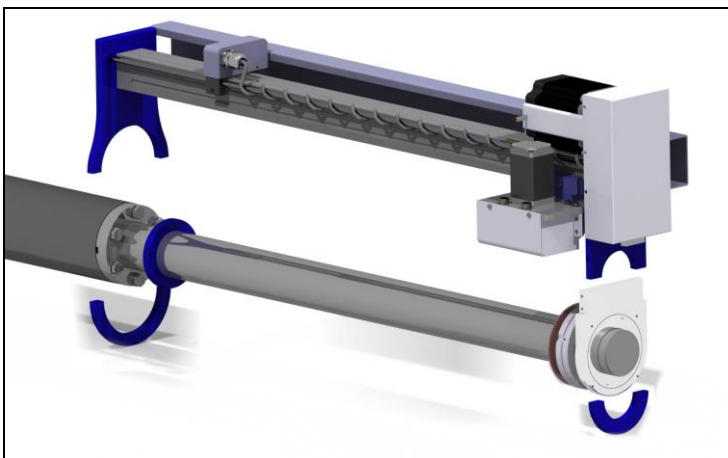

All UHV sample transporters (including the RM40), without motorization, are bakeable up to 150°C. Do not remove the magnetic coupling for the bakeout procedure.

In order to minimize formation of residual gas, it is helpful to move the coupling back and forth during cooldown of the UHV system after bakeout.



CAUTION! **Never** remove the magnetic coupling for the bakeout procedure. Make sure it's temperature **never** exceeds **150°C!**

4. Problem solving

4.1. Factory overhaul

The slide and ball bearings are the only parts of the sample transporter that wear out. Many bakeout periods lead to slight deformation of the slide bearings. This could result into disturbances of the motion smoothness and probably higher outgassing rates. We offer an full factory overhaul for inner and outer bearings and readjustment of any style of pincer grip. For more information please contact us directly.

4.2. Declaration of decontamination

In case of returning the sample transporter to us, it is necessary to complete a declaration of contamination and send it to us. Please contact us for this.

4.3. Download

This manual can be downloaded from our website. It can be found in the specifications of each listed sample transporter motorization.