

FERROVAC

ULTRA HIGH VACUUM TECHNOLOGY

LSA3.1 – Battery Operated High Voltage Controller for UHV Suitcases and Ion Getter Pumps



Operating Instructions

Revision B [February, 2023]

Ferrovac AG
Thurgauerstrasse 72
CH-8050 Zürich

Phone +41 44 273 16 38
sales@ferrovac.com
www.ferrovac.com

**Important!**

It is the sole responsibility of all users to carefully read the operating instructions and to keep them safe. Read and follow all safety instructions carefully before using the product described in this document. Ferrovac AG declines any and all responsibility and liability for any damage/injuries resulting from the use of incorrect adjusting of the product.

Warranty

Ferrovac AG warrants this product to be free of defects in material and workmanship for a period of 24 months from the date of shipment. In case of proof of any defective parts in the product, we will at our option, either repair the product or replace it.

Warranty limitations

The warranty for this product does not apply to defects resulting from the following:

- Non-observance of operational- and safety instructions
- Natural wear of components
- Consumables
- Modifications to our products without our written consent
- Misuse of any product or part of the product

This warranty stands in place of all other warranties, implied or expressed, including any implied warranty of implied merchantability or fitness for a particular use. The remedies provided herein are buyer's sole and exclusive remedies.

Neither the company Ferrovac AG nor any of its employees shall be liable for any direct, indirect, incidental, consequential or special damages arising out of the use of its products, even if the company Ferrovac AG has been advised in advance of the possibility of such damages. Such excluded damages shall include but are not limited to: Costs of removal and installation, losses sustained as the result of injury to any person, or damage to property.

Copyright

Copyright 2019, Ferrovac AG. All rights reserved. All information in this document is the sole property of Ferrovac AG and is protected by Swiss copyright laws and international conventions. Ferrovac AG grants the right for reproduction for the purchasers own use. No part of this manual may be reproduced or transmitted by any third party in any form or by any means and for any purpose without the written permission of Ferrovac AG.

1	General Information.....	4
1.1	Designated Use.....	4
2	Terms and Symbols	5
3	General Safety Information.....	5
4	About.....	7
4.1	Dimensions.....	7
4.2	Panel Description and Connections.....	8
4.3	Specifications.....	9
5	Unpacking and Inspection	10
5.1	Installation.....	10
5.2	Controller Power Management.....	10
5.3	Connecting the Ion Pump.....	10
5.4	Connecting the Temperature Cable	10
6	Operation	11
6.1	Start-up.....	11
6.2	Charging the Battery.....	11
6.3	Shut-down.....	11
7	Display Functionality	11
7.1	Normal Mode	11
7.2	Alarms.....	12
7.3	Display Light.....	12
8	Transport and Packing.....	12
9	Storage and Disposal.....	12
10	Digital Interface and Programming.....	13
10.1	Read Data.....	13
10.2	LSA ON.....	13
10.3	LSA OFF.....	13
10.4	Software	14
11	Maintenance	15
12	Performance Data	16
12.1	Battery Charge Time	16
12.2	Battery Discharge Time	16
12.3	Load Curve.....	16

12.4	Current-Pressure Relationship.....	17
13	Additional Information.....	18
13.1	Repair and Return of Defective Items	18
13.2	Downloads.....	18
13.3	CE Conformity Sheet.....	19

1 General Information

This manual covers all important information about installation, commissioning and operation of your LSA Battery Operated High Voltage Controller for UHV Suitcases and Ion Getter Pumps. It also provides important safety information, maintenance- and fault finding procedures.

The product described was manufactured in accordance with the applicable national standards and guidelines. The information in this document represents the state of the product at the date of print. Technical changes may be made without notice. Ferrovac AG makes no warranties or representations with respect to accuracy or completeness of the contents of this publication. Figures and photos are not binding. The product names used are for identification purposes and may be trademarks of their respective companies.

1.1 Designated Use

The product described in this document may only be used for its designated application. Designated use of the product is exclusively given if the following rules are obeyed:

- Product is used with original parts supplied by Ferrovac which are explicitly specified for the use with the product described in this publication
- In an indoor research laboratory environment or an industrial production or processing facility
- With all cabling connected and secured, if applicable
- By personnel qualified for operation of delicate scientific equipment
- In accordance with all related manuals.









Important!

Carefully read all safety instructions and all relevant manuals before using the product and any related equipment!

Non-designated use is given if the following is true:

- Product is used with other equipment not explicitly acknowledged by Ferrovac in writing
- Product is used outdoors or at ambient conditions exceeding the values given in the product specification
- Product is used by non-qualified persons
- Operation of the product in disregard of the safety instructions
- Operation of the product with disabled, modified, removed or damaged safety equipment and devices.

2 Terms and Symbols

Symbol	Term	Meaning
	Danger!	Risk of mortal danger when not observed
	Warning!	Risk of severe injury or danger to life when not observed
	Caution!	Slight risk of injury or damage to product when not observed
	High voltage!	Potentially lethal voltages are present
	Cryogenic Substances!	Potential cold burn hazard if safety precautions are not followed
	Important!	Important information for proper operation of the product
	Info, hint!	Useful hints, tips and clues

3 General Safety Information

Read the safety instructions very carefully. All safety precautions must be strictly observed at all times before using the product described in this manual and any associated instrumentation.

Study this document to learn how to operate your product properly. Keep this instruction manual in a safe place close to the described product and inform all other users of the product. Always include this manual when handing the product over to third party persons.

Responsible body is the individual or group of persons that are responsible for the proper use and maintenance of the product, ensuring that the product is operated within its specifications and operating limits. The responsible body must ensure that users of the product are adequately trained.

Operators are using the product for its intended purpose. Users must be trained in electrical safety, handling of cryogenic liquids and adequate use of the instrument. They must be protected from electric shock and contact with potentially dangerous situations.

Maintenance Personnel perform routine tasks on the product to keep it in proper operating conditions i.e. setting up the line voltage or replacing consumables. Maintenance procedures are described in this manual and must be followed at all times.

Service Personnel are trained to work on live circuits and to work cryogenic liquids as well as perform fault finding measurements and repair work to the product. Only fully trained service personnel qualified to handle potentially lethal voltages may perform servicing and repair.

Shock hazard: The American National Standards Institute states that a shock hazard exists when voltage levels are greater than 30 V RMS, 42.2 V peak or 60 VDC. A good safety practice is to assume that hazardous voltages are present in any unknown circuitry.



Warning!

Any adjustment, fault finding procedure, installation and maintenance of the products described in this manual must be carried out only by authorized personnel, fully qualified to handle potentially lethal voltages.



Warning: High Voltages up to 5kV!

- Always observe and strictly follow the safety notes and regulations given in this document.
- Always use the configured cables delivered with the product for electrical connections.
- Never operate the high voltage supply when the ion pump is not connected and under vacuum.
- Never operate the ion pump in a pressure range above 1E-5 mbar.
- Never operate the device outside its dedicated environment.
- Always strictly follow the safety notes and regulations.
- DO NOT OPEN the device unless you fulfill the requirements of a fully trained service personnel and you are familiar with ultra-high vacuum products.



Important! Ambient conditions and environment:

This product is only to be used indoors, in locations meeting the following requirements:

- Room temperature lies between 5 °C/41 °F and 40 °C/104 °F
- Humidity up to maximum of 80 %
- Altitudes up to 2000 m
- Pollution Degree 2 environments

4 About

The LSA is a battery powered ion pump controller which allows an operation of an ion pump without mains power supply for many hours. This unit is in particular suitable for mobile ultra high vacuum chambers which can be connected to different systems in a laboratory. The LSA is designed to operate ion pumps which fulfill the respective requirements for a supply voltage of 5 kV and a maximum current of 100 μ A. The device is powered by a Nickel metal hydride (Ni-MH) rechargeable battery such that the controller can independently run up to 40 h. The battery is charged by an external power supply. The LSA measures the current of the ion pump and displays the pressure. It is optimized for a NEXTorr® D100-5 or NEXTorr® D200-5 pump from SAES unless you clearly define these other pumps. The LSA is designed to operate diode ion pumps which require positive output polarity.



Caution!

Please note that the polarity has to be correct for your pump!

4.1 Dimensions

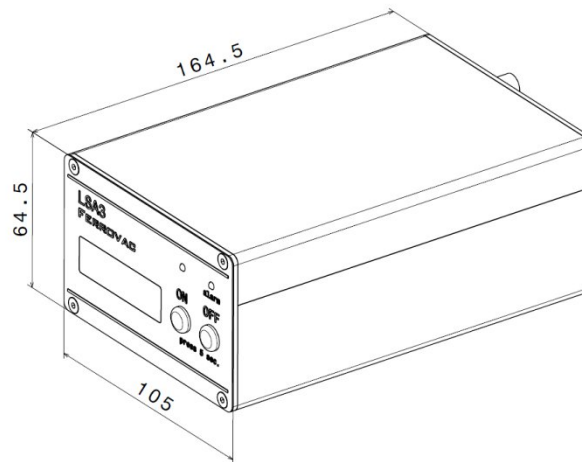

(All dimensions in mm)

4.2 Panel Description and Connections

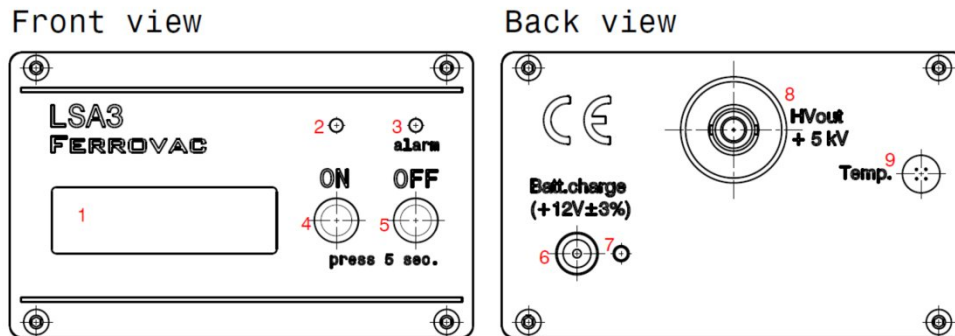

1. Display
2. Status LED (blue) indicating power availability
3. Alarm LED (red) indicating an alarm for low battery or temperature readout above 150 °C
4. Power Output ON Switch
5. Power Output OFF Switch
6. External Power Supply Connector
7. Charging Power LED
8. High Voltage Output Connector (HUBER&SUHNER SHV type) to Ion Pump
9. Temperature Sensor Input Connector (4 pole)

4.3 Specifications

- **Ambient Conditions:**
 - Temperature: 5 °C to 40 °C
 - Relative Humidity: maximum 80% for temperatures up to 31 °C, decreasing linearly to 5% relative humidity at 40 °C
 - Altitude: up to 2000 m

- **Charging Device:**
 - Input: 100 – 240 VAC, 50/60 Hz
 - Mains Voltage fluctuation: ±10 % max.
 - Output: +12 VDC (±5 %)

- **Input (Battery Charge):**
 - Voltage: +12 VDC (±5 %)

- **Battery:**
 - Type: Ni-MH (Nickel metal hydride)
 - Discharge Time: approx. 40 h at 5 µA load current
 - Charging Time: approx. 8 hours
 - Battery Life Span: approx. 1000 cycles

- **Output:**
 - High Voltage Output: +5 kV DC (±10 %)
 - Current: 100 µA max.
 - Source Resistance: >10 MΩ
 - Output Connector: Kings HV connector, max. 10 kV DC

- **Pump Capacity:** Diode ion pumps with a load current <100 µA.
Please refer to the current to pressure diagram of the pump manufacturer.

- **Temperature Measurement:**
 - Sensor Type: Pt100
 - Supply Current: 1 mA
 - Temperature Range: -200 °C to 150 °C, ±2.5 °C

5 Unpacking and Inspection

Before unpacking, optically inspect the parcel. If damage is found, take pictures of the parcel and send them to Ferrovac AG immediately. Compare content with the order list. The package should contain following products, but may vary upon specific customer requests:

1. Battery powered ion pump controller
2. Battery charger including 4 power adapters
3. This manual and any manuals of additional subunits, if applicable.

Any damage or missing item must be reported to Ferrovac **within 48 hours after arrival of the items**.

5.1 Installation

Put the LSA on a solid table, such that it cannot fall down. When connecting any cables, ensure that they cannot become a tripping hazard for people working nearby or that anybody could tear down the LSA controller.

The battery charger:

- The LSA must be charged using the delivered 12VDC $\pm 5\%$ power adapter
- Use the correct mains adapter plug for your country and install it on the power adapter
- Connect the LSA unit to a mains socket (not exceeding voltage fluctuations of $\pm 10\%$)
- Connect the cable of the 12 VDC power adapter to the LSA power input. The red LED in the front panel lights up when the power adapter is connected.

5.2 Controller Power Management

Before using the Ion Pump controller for the first time, the internal battery must be charged for approximately 5 h. The fully charged controller will run up to 60 h on internal battery supply. The lifespan of the batteries, with correct charging and discharging, is approximately 1000 charge cycles.

5.3 Connecting the Ion Pump



Caution!

Only connect or disconnect HV cables when the LSA controller is switched off. Only use an original cable rated for at least 5 kV DC supplied with the LSA unit.

Make sure that the LSA is switched off. Connect the pump to the “HVout” output connector using the originally supplied high voltage cable with the correct HV coaxial connector. The cable must be fully intact (refer to the maintenance section).

5.4 Connecting the Temperature Cable

The cable for temperature measurement is connected to the 4 pole output connector called “Temp”. When no temperature cable is connected, the display will show “noTemp”.

6 Operation



Important!

Ferrovac AG declines any and all responsibility and liability for any damage resulting from incorrect use or incorrect adjustment of the product.

6.1 Start-up

For starting the controller, press and hold the controller power ON switch for 5 seconds. At the same time the blue status LED will light up.

NOTE: The LSA controller output is short circuit proofed. Current overload $>100 \mu\text{A}$ will result in an approximately linear decrease of the output voltage (see also performance data in section 12 Performance Data).

NOTE: At start-up of a pump, it might take some time until the pump reaches its normal working condition. Therefore the current drops usually during the first minutes from a high value. Please refer to the respective manual of the pump.

6.2 Charging the Battery

The charger for the battery can be connected whenever it is needed. It is not necessary to switch off the LSA. When the battery has come to its minimum level, the LSA will switch off automatically. This automatically prevents an absolute discharge of the battery. It takes about 8 hours without a pump connected to fully recharge the LSA.

6.3 Shut-down

For shutting down the controller, press and hold the power OFF switch for 5 seconds. The high voltage at the output connector will decrease to zero level after approximately 1 minute, depending on the load current.

7 Display Functionality

7.1 Normal Mode

At start-up, the display shows a starting message. Afterwards, it will automatically switch to the normal mode showing the pressure in mbar, battery state and temperature (if applicable) in °C. The battery indicator has three bars (Bat: □□□) to show the battery status. When the battery discharges, the boxes will vanish until (Bat: _ _ _) is shown. When the battery is fully charged, the three bars in the display will become black (Bat: ■■■). Then the power adapter can be taken off. When the battery starts discharging, the bars will be open again. If the pressure is too low and cannot be measured properly anymore, the display will show "P UNDERRANGE". This also happens if no ion pump is connected with the controller.

7.2 Alarms

When the controller detects a low battery voltage it beep for about 1 minute, and the display will show "Bat low". Battery power is maintained for about another 2h. The red alarm LED will blink until the batteries are charged again or the LSA is switched off. When the battery has come to its minimum level, the LSA will switch off automatically.

Display	Meaning
Bat: ■■■	Battery fully charged
Bat: □□□ Bat: □□_ Bat: □_ _	Battery discharging
Bat: _ _ _	Battery has 8-10 hours left
Bat low	Together with beeping: The battery should be charged soon again, about 2 hrs remaining before the LSA will automatically switch off
noTemp	No temperature sensor connected
T= 155°C	Temperature display
P UNDERRANGE	Pressure is too low to be measured
P OVERLOAD !	Detected pressure is too high, device in overload

In case of a temperature above 150°C the LSA will beep for about 1 minute and the red alarm LED will blink. Once the temperature drops below 150°C again or the temperature sensor cable is disconnected, the alarm stops automatically.

7.3 Display Light

At start-up, the display background light is illuminated and will switch off after about 10 seconds to save battery power. The display background light can be switched on again by quickly pressing the "ON" button. It switch off after 10 seconds again. It also can be manually switched off by pressing the "ON" button a second time.

8 Transport and Packing

During transport outside a laboratory environment for longer distances, the device must be switched off. The LSA must be carried by hand or in an appropriate package. The operator needs to make sure that the LSA cannot be switched on unintentionally. The inner contact of the HV connector must always be protected against accidental contact. The device must be protected from mechanical shocks.

9 Storage and Disposal

Before removing the HV cables, the LSA must be switched off. The device must be stored in a safe place where it cannot fall or be switched on unintentionally (accidentally pressing the ON button must be prevented). The cables can be gently coiled without making any kinks. In order to maintain the lifespan of the batteries, it is advisable not to fully discharge the batteries during storage.

All electronic equipment must be disposed properly into electronic waste to be recycled at safely managed sites according to the local laws.

10 Digital Interface and Programming

The LSA has a USB port allowing digital interfacing. Principle aspects of this interface are:

- Baud Rate (9600)
- Data Bits (8)
- Parity (None)
- Stop Bit (1)



1. Vcc (+5V)
2. Data -
3. Data +
4. NC
5. GND

In order to communicate with the LSA unit, plug in your board and wait for Windows to begin its driver installation process. If the installer does not launch automatically, navigate to the Windows Device Manager (Start>Control Panel>Hardware) to find the Arduino Micro listing. Right click and choose Update driver.

To control and readout the data of the LSA, any serial terminal emulator software (such as Tera Term or Putty) can be used.

10.1 Read Data

Command: "A"

This command will return a data string with all information from the LSA. The data are separated with ",".

Response Format: "LSA, Ion Pump Current in nA, Pressure in mbar, Temperature in °C, Battery Power in V,"

Example: "LSA3,16856,2.9E-7,23,0.00,"

10.2 LSA ON

Command: "B"

This command will turn on the LSA and will take about 2-3 seconds to execute. The following response will be sent after execution:

Response: "LSA is ON"

10.3 LSA OFF

Command: "C"

This command will turn off the LSA and will take about 2-3 seconds to execute. The following response will be sent after execution:

Response: "LSA is OFF"

10.4 Software

Ferrovac provides customers with an executable application; however, it is only available for **Windows 8 and above** versions. The LSA Application program will be sent by Ferrovac to the customers as an **.exe** file. The processes on how to download and use the software are described in a separate manual (LSA3.0(USB) Software). In case you have questions about the additional manual and/or software, please contact Ferrovac directly.

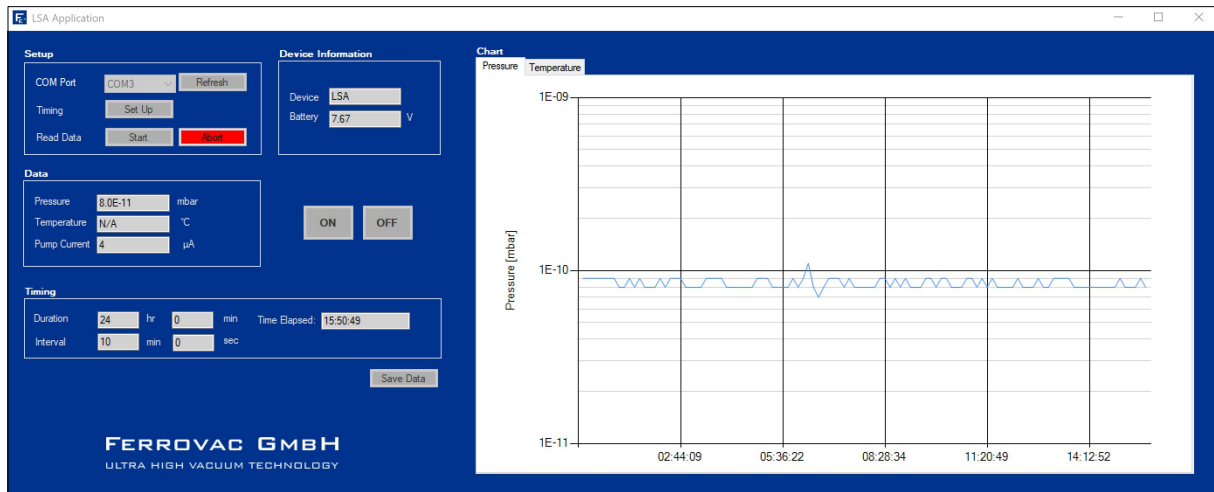

11 Maintenance



Warning!

The outer shield of the HV cable has to be intact which can be easily verified by measuring the resistance between outer metallic parts from one plug to the other. It must be below 100 mΩ.



Warning!

The operator is not allowed to open the device and perform any maintenance tasks.

It is very important that the shield of the HV cable is intact. Please check the cable regularly for damages on the outer insulation or for any kinks. The HV cable should be checked regularly to make sure that the insulation is not damaged and there are no kinks in the cables. The outer shield of the HV cable has to be intact which can be easily verified by measuring the resistance between outer metallic parts from one plug to the other. It must be below 100 mΩ.

With time of use, the battery storage capacity will decrease. The battery should be replaced after a period of 1000 charge/discharge cycles, as the number of discharge and charge cycles has an effect on the lifetime.

Return the controller for a battery swap to Ferrovac AG. If this is not possible please contact Ferrovac AG for instructions. Only in exceptional cases Ferrovac AG and the **Responsible Body** can agree that a fully trained **Service Personnel** will receive special instructions to perform a particular maintenance task.

12 Performance Data

12.1 Battery Charge Time

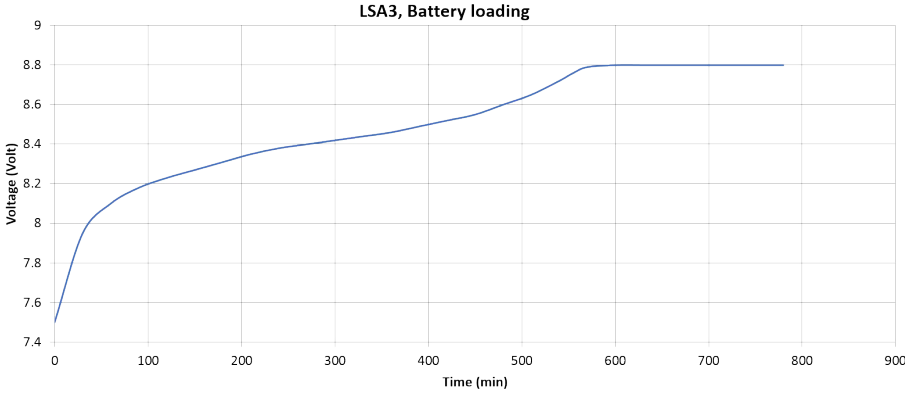

12.2 Battery Discharge Time

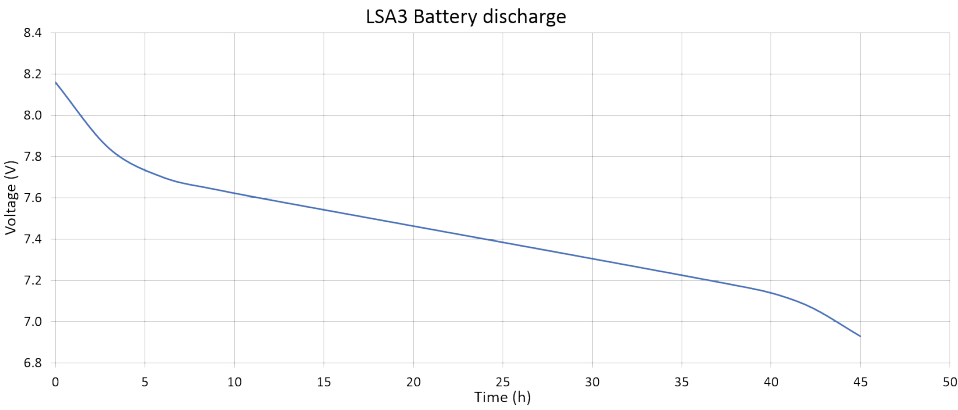

12.3 Load Curve

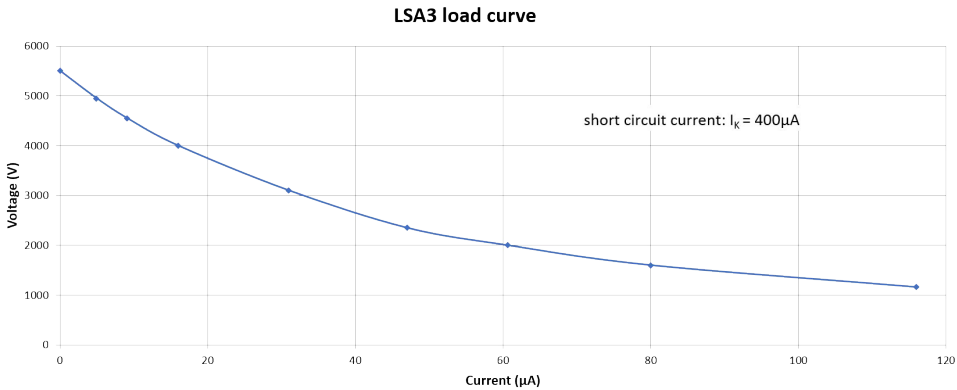

12.4 Current-Pressure Relationship

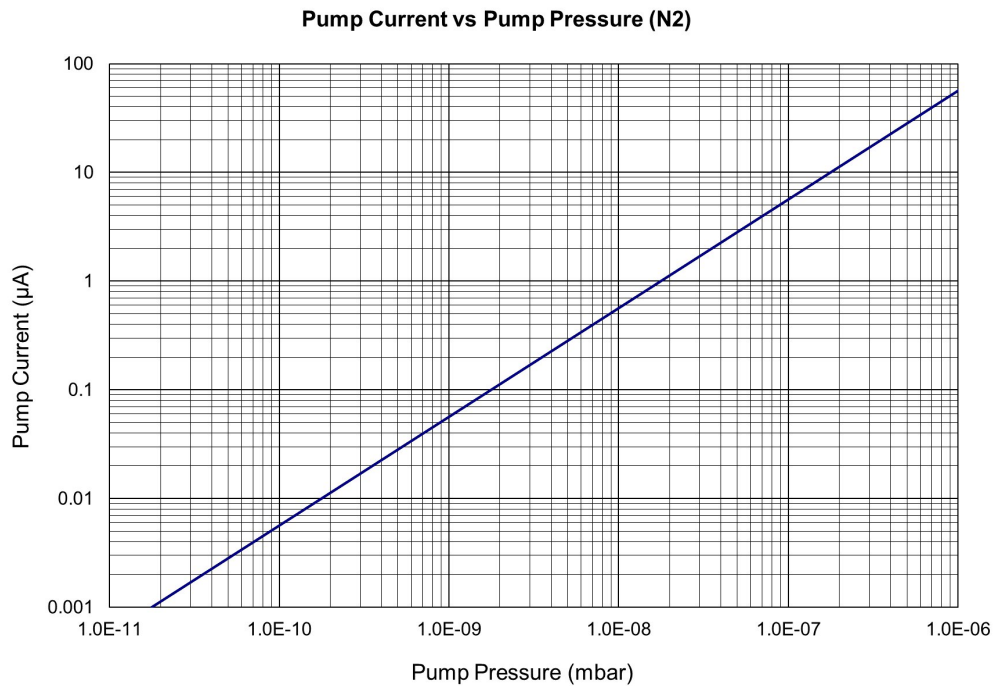

The LSA shows the pressure directly. For most pumps the current is directly proportional to the pressure in the pump (vacuum system). The diagram provides the current to pressure conversion curve of the following pump models:

SAES NEXTorr® pumps:

- D100-5
- D200-5
- D300-5
- D500-5

For other ion pump models, please refer to their manual.

13 Additional Information

13.1 Repair and Return of Defective Items



Important!

Do not factory return any items without Return of Materials Authorization (RMA) form provided by Ferrovac AG. Please contact us beforehand.



Ferrovac AG will issue a required RMA (Return of Materials Authorization) form, before any items are factory returned. Please contact us beforehand. You will be given an RMA number and information on how to proceed with the return of defective items.

13.2 Downloads

The latest version of this manual can be downloaded from our website www.ferrovac.com. For any suggestions or questions concerning this manual, please don't hesitate to contact us.

Ferrovac AG
Thurgauerstrasse 72
8050 Zürich
Phone: +41 (0) 44 273 16 38
E-Mail: sales@ferrovac.com
Website: www.ferrovac.com

13.3 CE Conformity Sheet

<p>EU declaration of conformity</p> <p>The manufacturer / authorised representative</p> <p>Ferrovac GmbH Thurgauerstrasse 72 8050 Zürich Switzerland</p> <p>hereby declares that the following product</p> <table border="1"><tr><td>Product designation:</td><td>Battery Powered Ion Pump Controller</td></tr><tr><td>Make:</td><td>LSA3.0/LSA3.0B</td></tr><tr><td>Description:</td><td>The LSA3 is a battery powered ion pump controller designated to operate ion pumps which fulfill the respective requirements for a supply voltage of 5kV and a maximum load current of 100µA. The device is powered by a Ni-MH rechargeable battery such that the controller can run up to 40h independently of an external electricity supply. The battery is charged by an external power supply which can be connected to the LSA3. In addition the LSA3 has a temperature measurement unit to connect a Pt100 sensor.</td></tr></table> <p>fulfills the regulations of the directive 2011/65/EU of the European Parliament and Council from 8th June 2011 on the restriction of the usage of certain hazardous substances in electrical and electronic devices.</p> <p>The following additional EU directive has been applied: EMC Directive 2014/30/EU</p> <p>The following harmonised standards have been applied:</p> <ul style="list-style-type: none">EN 50581:2012 Technical documentation for the assessment of electrical and electronic products with respect to the restriction of hazardous substancesEN 55011:2016 Industrial, scientific and medical equipment - Radio-frequency disturbance characteristics - Limits and methods of measurement (CISPR 11:2015 modified)EN 61010-1:2010 Safety requirements for electrical equipment for measurement, control, and laboratory use - Part 1: General requirements (IEC 61010-1:2010) <p>Place: Zürich, Switzerland Date: 2017-09-14</p> <p> (Signature) David von Gunten (COO)</p>	Product designation:	Battery Powered Ion Pump Controller	Make:	LSA3.0/LSA3.0B	Description:	The LSA3 is a battery powered ion pump controller designated to operate ion pumps which fulfill the respective requirements for a supply voltage of 5kV and a maximum load current of 100µA. The device is powered by a Ni-MH rechargeable battery such that the controller can run up to 40h independently of an external electricity supply. The battery is charged by an external power supply which can be connected to the LSA3. In addition the LSA3 has a temperature measurement unit to connect a Pt100 sensor.	
Product designation:	Battery Powered Ion Pump Controller						
Make:	LSA3.0/LSA3.0B						
Description:	The LSA3 is a battery powered ion pump controller designated to operate ion pumps which fulfill the respective requirements for a supply voltage of 5kV and a maximum load current of 100µA. The device is powered by a Ni-MH rechargeable battery such that the controller can run up to 40h independently of an external electricity supply. The battery is charged by an external power supply which can be connected to the LSA3. In addition the LSA3 has a temperature measurement unit to connect a Pt100 sensor.						