

**Rot. Endswitch 1**

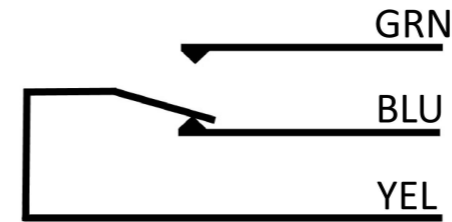

**Reed Endswitch (Front)**

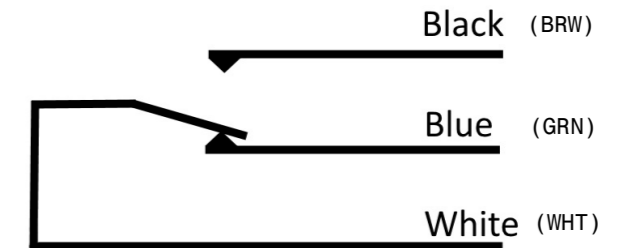

D-Sub Pin	Function	
1	Linear Motor	(A) BLK
2	Linear Motor	BLK/WHT
3	Linear Motor	BLU/WHT
4	Rotary Motor	(A) BLK
5		
6	Rot. Endswitch 1	GRN
7	Rot. Endswitch 2	BLK
8	Endswitch (Back )	1
9	Reed Endswitch (Front)	Blue
10	Linear Motor	(A/) GRN
11	Linear Motor	GRN/WHT
12	Linear Motor	(B/) BLU
13	Rotary Motor	(A\ ) GRN
14		
15	Rot. Endswitch 1	YEL
16	Rot. Endswitch 2	WHT
17	Endswitch (Back )	2
18	Reed Endswitch (Front)	White
19	Linear Motor	(B) RED
20	Linear Motor	RED/WHT
21	Rotary Motor	(B) RED
22	Rotary Motor	(B\ ) BLU
23		
24	Rot. Endswitch 1	BLU
25	Rot. Endswitch 2	RED
26	Reed Endswitch (Front)	Black

**Rot. Endswitch 2**

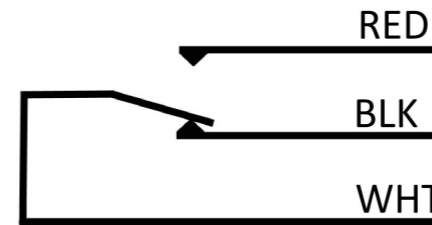

**Endswitch (Back)**



**Rotary Motor Schematic**

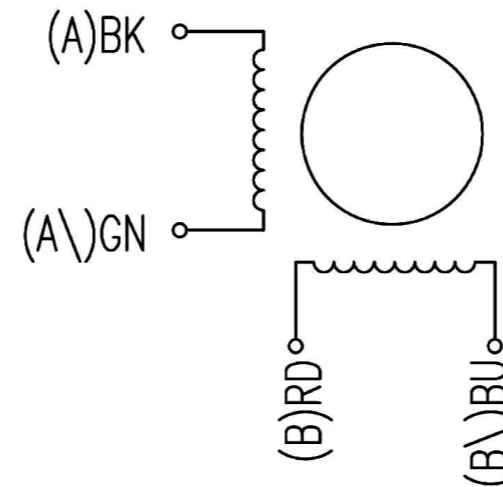

**Linear Motor Schematic**

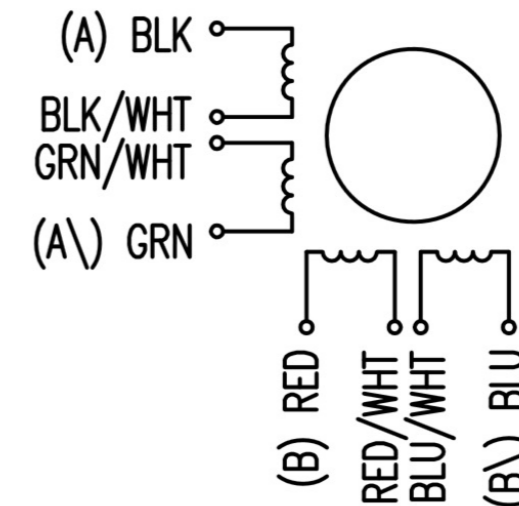

Material: ....	nominal dimension	over up to	1	6	30	100	300	1000
			6	30	100	300	1000	2000
	tolerance	±	0.05	0.1	0.3	0.5	0.8	1.2
Motorized Linear/Rotary Drive RM	Scale	Drawn	C.Weiss					
DRVRMOTLR		Date	13.01.2015					
		Changed	.....					
<b>Ferrovac GmbH</b>	1:2	DRVRMOTL - XXXX						
CH-8050 Zurich	Rev. A	A3 sheet 2/3						

THE INFORMATION CONTAINED IN THIS DRAWING IS THE SOLE PROPERTY OF FERROVAC GMBH. ANY REPRODUCTION IN PART OR AS WHOLE WITHOUT OUR PERMISSION IS PROHIBITED.