

Front view and mounting

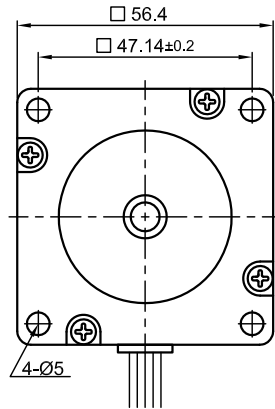

Side view

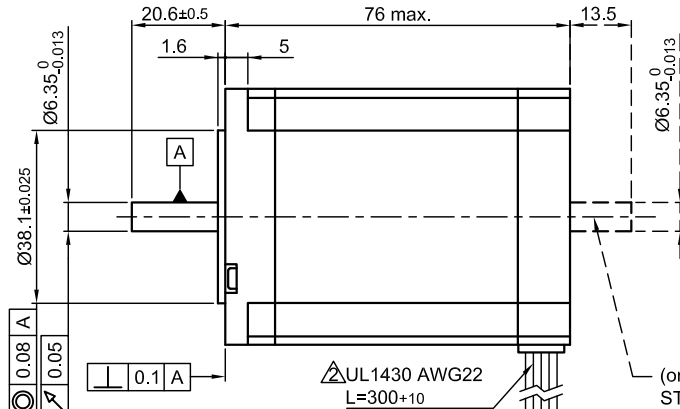

Rear view

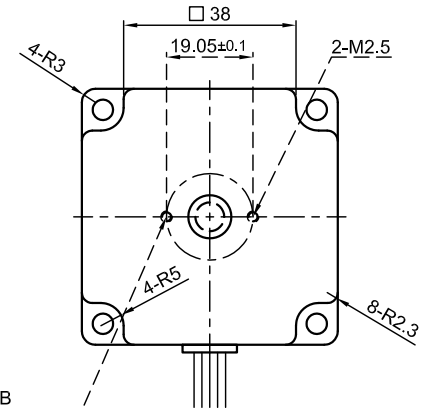

UL1430 AWG22 L=300+10
Connector Type: JST XHP-8
Contact: SXH-001T-P0.6
(only for type ST5918L1008-B Ready for encoder+ driver mount)

SPECIFICATION	CONNECTION	UNIPOLAR OR BIPOLAR-1 WINDING	BIPOLAR	
			SERIAL	PARALLEL
VOLTAGE (VDC)		8.8		
AMPS/PHASE		1.0	0.71	1.41
RESISTANCE/PHASE (Ohms)@25°C		8.8±10%	17.6±10%	4.4±10%
INDUCTANCE/PHASE (mH) @1KHz		19±20%	76±20%	19±20%
HOLDING TORQUE (Nm) [lb-in]		1.32 [11.71] Δ	1.87 [16.52] Δ	1.87 [16.52] Δ
DETENT TORQUE (Nm) [lb-in]		0.068 [0.602]		
STEP ANGLE (°) ± ACCURACY		1.8±5% (NON-ACCUM)		
ROTOR INERTIA (Kg-m ²) [lb-in ²]		4.8x10 ⁻⁵ [0.164]		
WEIGHT (Kg) [lb]		1.0 [2.2]		
TEMPERATURE RISE: MAX.80°C (MOTOR STANDSTILL; FOR 2 PHASE ENERGIZED)				
AMBIENT TEMPERATURE -10~ 50°C [14°F ~ 122°F]				
INSULATION RESISTANCE 100 MOhm (UNDER NORMAL TEMPERATURE AND HUMIDITY)				
INSULATION CLASS B 130° [266°F]				
DIELECTRIC STRENGTH 500VAC FOR 1 MIN. (BETWEEN THE MOTOR COILS AND THE MOTOR CASE)				
AMBIENT HUMIDITY MAX. 85% (NO CONDENSATION)				

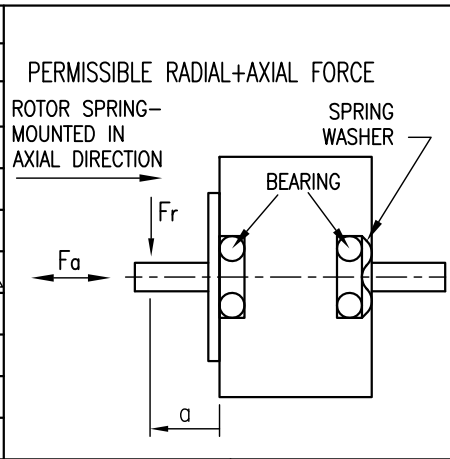

AXIAL-FORCE Fa (N)	Fa=15			
	5	10	15	20
DISTANCE a (mm)	5	10	15	20
RADIAL-FORCE Fr (N)	130	90	70	52
		AXIAL	RADIAL	
SHAFT PLAY (mm)	0.08	0.02		
AT LOAD MAX: (N)	4.5	4.5		

TYPE OF CONNECTION (EXTERN)				MOTOR		
UNIPOLAR	BIPOLAR 1WINDING	BIPOLAR SERIAL	BIPOLAR PARALLEL	CONNECTOR PIN NO. Δ	LEADS	WINDING
A	A	A	A	1	BLK	A
COM	A			3	BLK/WHT	
A\	B	A\	A\	2	GRN/WHT	A\
B	B	B	B	4	GRN	B
COM	B			5	RED	
B\		B\	B\	7	RED/WHT	B\
				6	BLU/WHT	
				8	BLU	

FULL STEP 2 PHASE-Ex., WHEN FACING MOUNTING END (X)

STEP	A	B	A\	B\	CCW	CW
1	+	+	-	-	↓	↑
2	-	+	+	-	↓	↑
3	-	-	+	+	↓	↑
4	+	-	-	+	↓	↑

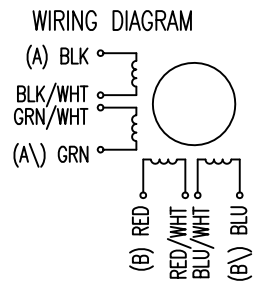

3	NEW VALUE OF HOLD. TOR.	04.11.13.	J.D.
2	UL NO.	17.07.09.	J.W.
1	PIN-ASSIGNMENT	04.01.08	J.W.
REV	DESCRIPTION	DATE	APVD

Nanotec
PLUG & DRIVE
ST5918L1008

SCALE FREE	APVD	S.Ha.	19.03.07
X ±0.5	CHKD		
1PL ±0.2	DRN	J.W.	21.11.06
2PL ±0.1	SIGNATURE		
ANGLE ±30'			

STEPPING MOTOR
DWG.NO ST5918L1008